

TerraRoc Down The Hole Hammer

With 3 1/2" API REG

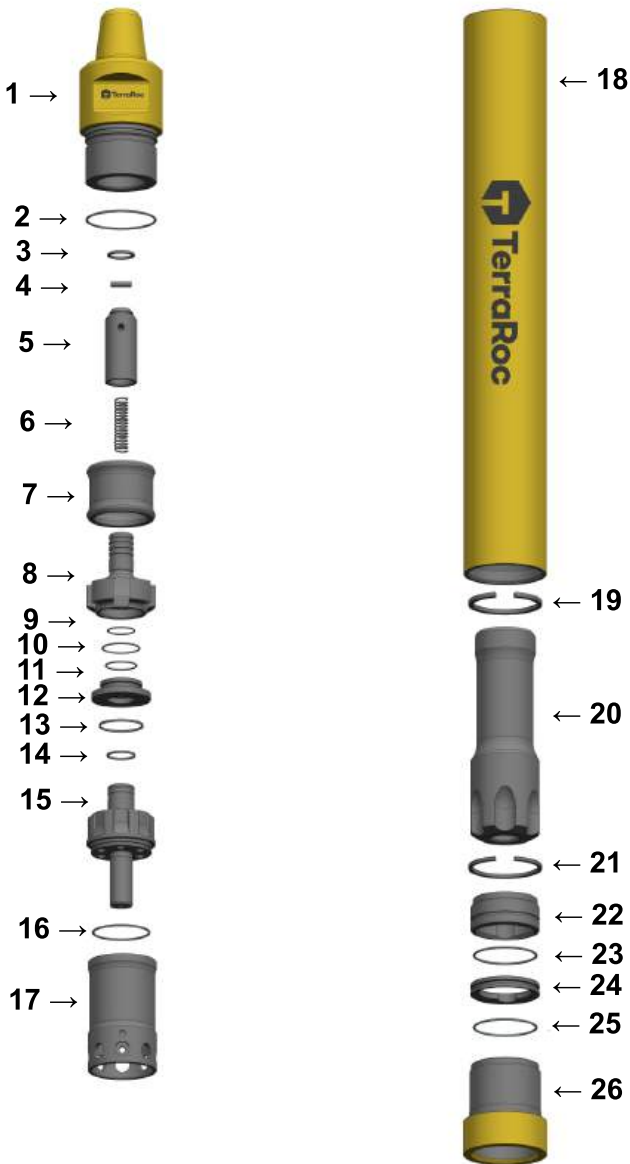

REF NO	DESCRIPTION	PART NUMBER
1	TOP SUB	34162001
2	O RING	34162002
3	CHECK VALVE SEAL	34162003
4	PLUG	34162004
5	CHECK VALVE	34162005
6	CHECK VALVE SPRING	34162006
7	SPACER	34162007
8	CHECK VALVE GUIDE	34162008
9	SPACER	34162009
10	CHECK VALVE GUIDE	34162009
10	SEAL VLIVE OD	34162010
11	O RING VALVE OD	34162010
12	SEAL VLVE ID	34162011
13	VALVE	34162012
13	O RING VALVE ID	34162013
14	O RING VALVE CAP	34162014
15	DISTRIBUTOR	34162015
16	O RING DISTRIBUTOR	34162016
17	LINER	34162017
18	CASING	34162018
19	RING	34162019
20	PISTON	34162020
21	PISTON RETAINING RING	34162021
22	BEARING	34162022
23	O RING BEARING	34162023
24	BIT RETAINING RING	34162024
25	O RING RETAINING RING	34162025
26	CHUCK	34162026

Air Consumptions		
Pressure	Ltrs/ Sec	SCFM
10 bar/ 145 psi	217	451
15 bar/ 217 pi	339	718
20 bar/ 290 psi	460	974
25 bar/ 362 psi	582	1232
30 bar/ 435 psi	700	1483
35 bar/ 508 psi	825	1738

GENERAL SPECIFICATIONS		
Drill Pipe Connection	3 1/2" API Reg	
Bit Shank Type	QL 60	
Length w/o shoulder to shoulder	1129 mm	44.46"
Length with bit extended	1267.6 mm	49.9"
Weight w/o bit	90.3	198.7 lbs
Backhead across flats	101.66 mm	4.0"
Button Bit size	152 - 203 mm	5" - 8"
Outside diameter	138 mm	5.44"
Piston Weight	19.0 kgs	41.9 lbs
Maximum Operating Pressure	35 bar	508 psi